



一级代理商：

深圳市弗瑞鑫电子有限公司

地址：深圳市宝安区西乡大道302号金源商务大厦B座三楼

frxelec



5. Abol e Ma im m Ra ing (Ta=25)

Pa ame e

S mbol Ra ed Val e

Uni

6. Electrical Optical Characteristics at Ta=25 C

Parameter		Symbol	Min	Typ.*	Max	Unit	Condition



7. O de Info ma ion

Pa N mbe

OR-M302X-W-Y-Z

o OR-M305X-W-Y-Z

No e

O ion	De c i ion	Packing an i

8. Naming Rule

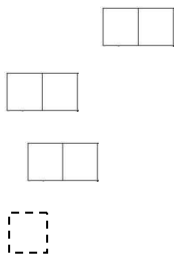
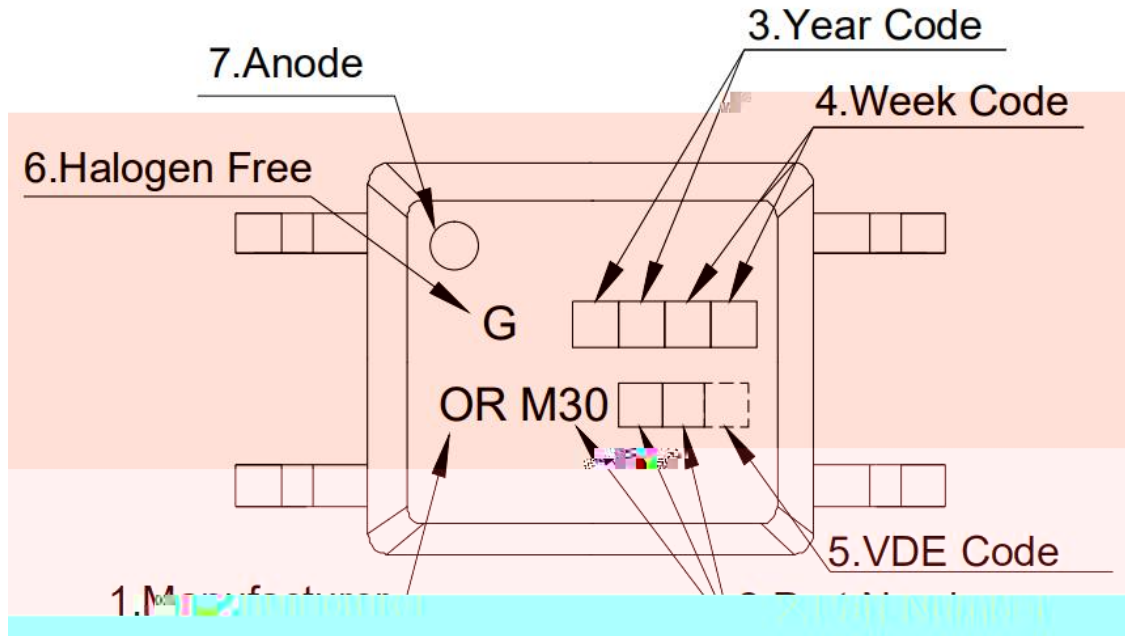

9. Package Dimension

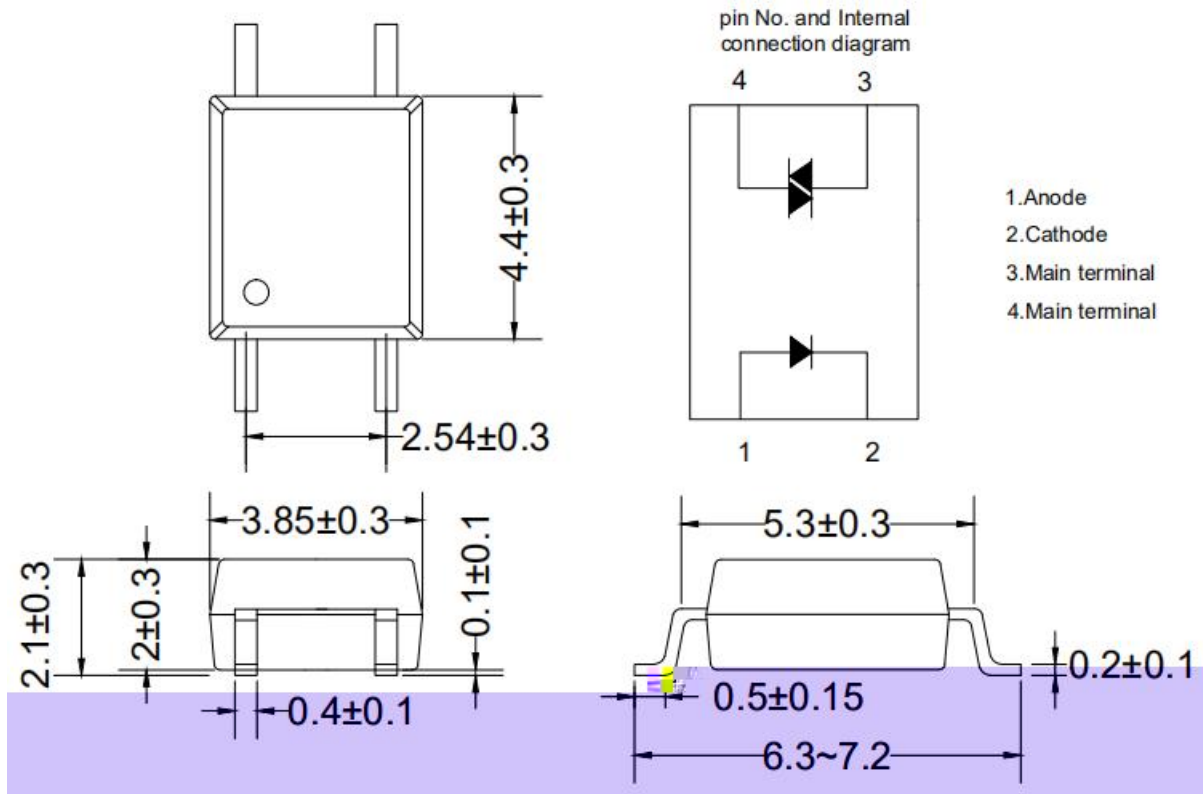

10. Recommended Foot Print Pattern (Mo n Pad)

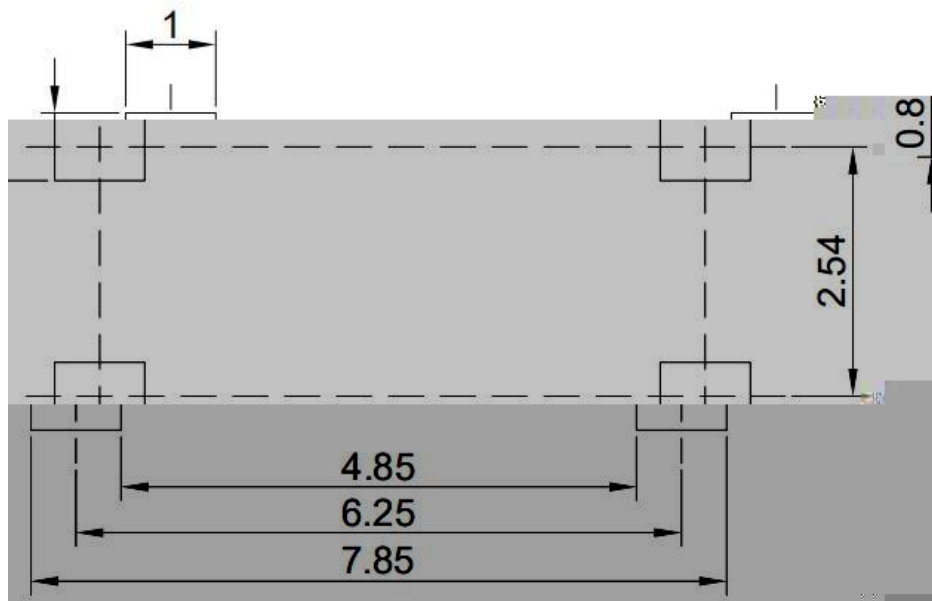

ni mm

11. Ta ing Dimen ion

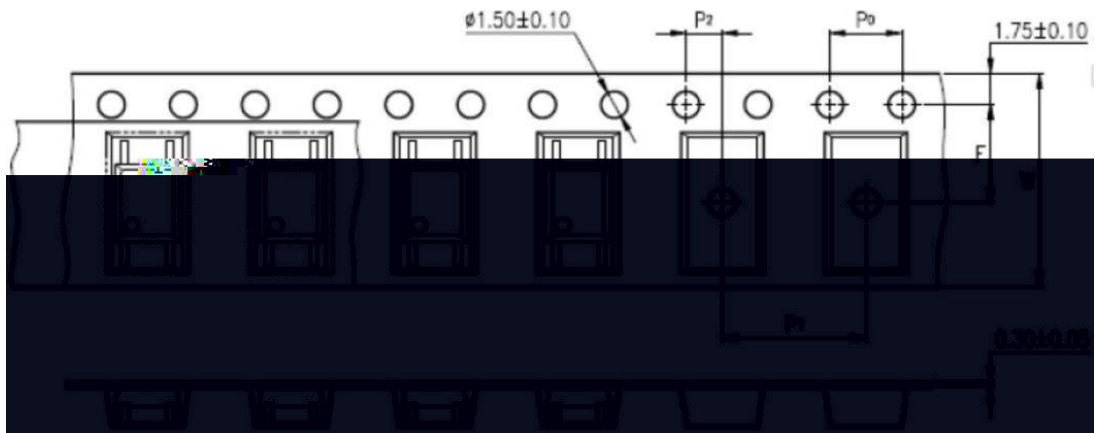
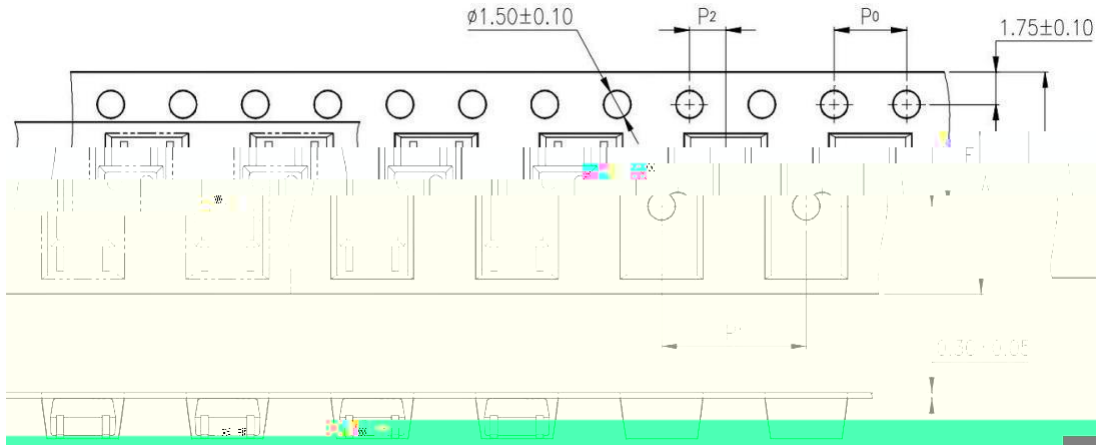



13. Temperature Profile Of Soldering

Profile Item	Condition
	

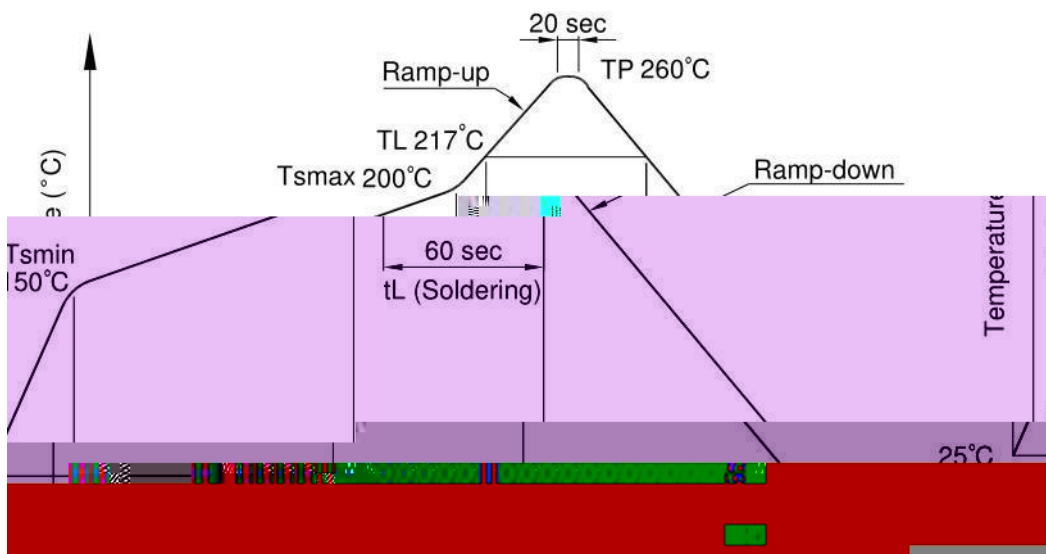

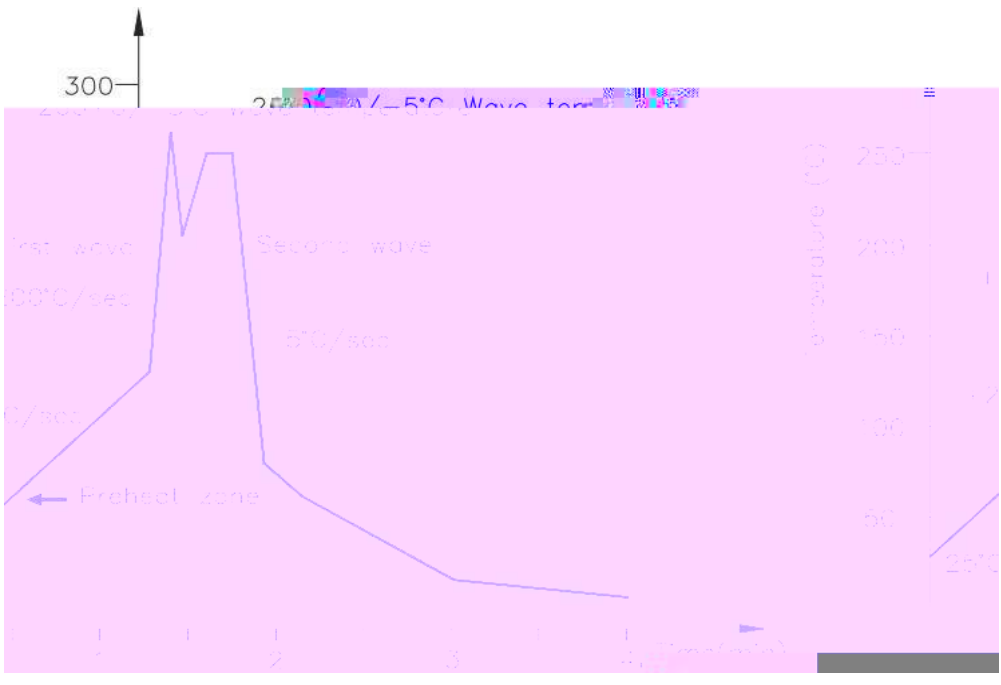

--	--

14. CHARACTERISTICS CURVES (TYPICAL PERFORMANCE)

Fig.1 Forward current vs Ambient temperature

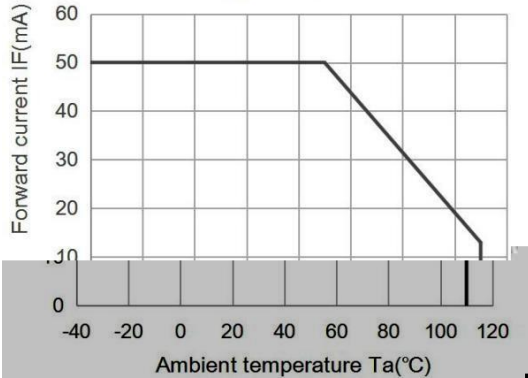

Fig.2 On-state current ITM (A) vs Ambient temperature

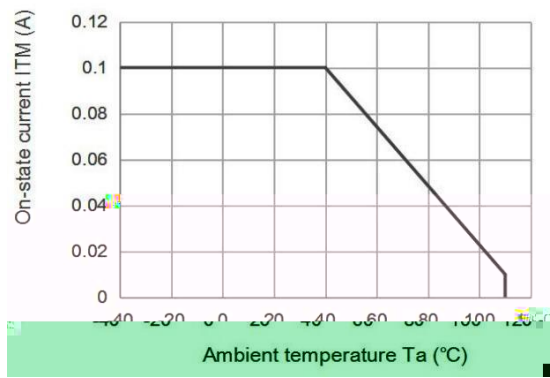

Fig.3 Minimum Trigger Current vs. Ambient temperature

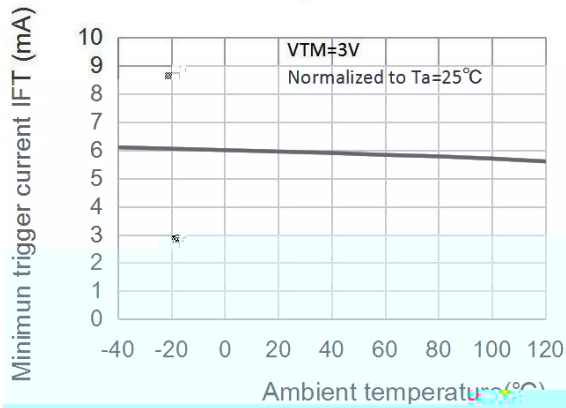

Fig.4 Forward current vs. Forward voltage

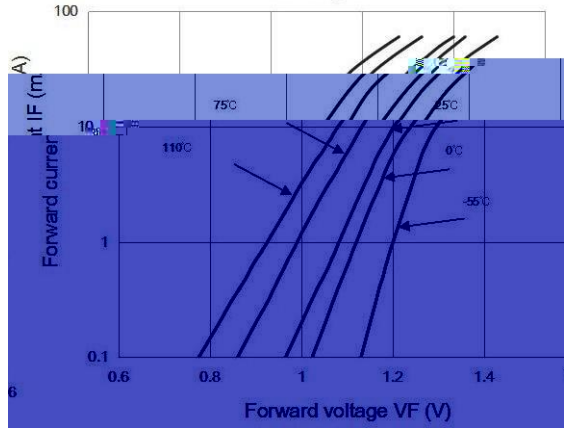

Fig.5 On-state voltage vs. Ambient temperature

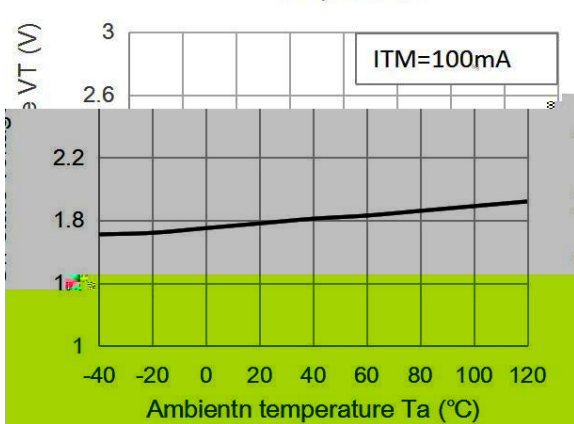

Fig.6 Holding current vs. Ambient temperature

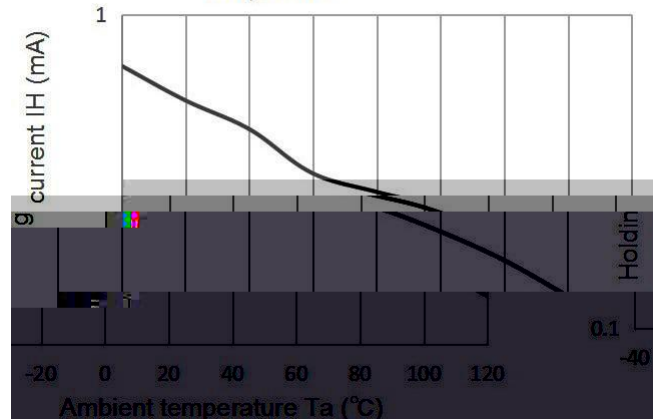

Fig.7 Repetitive peak off-state current vs. V_T

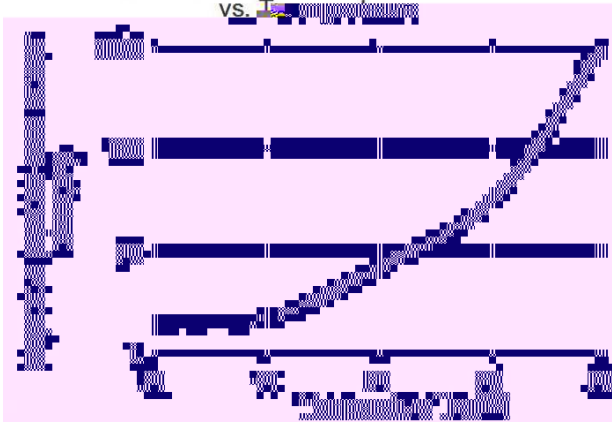
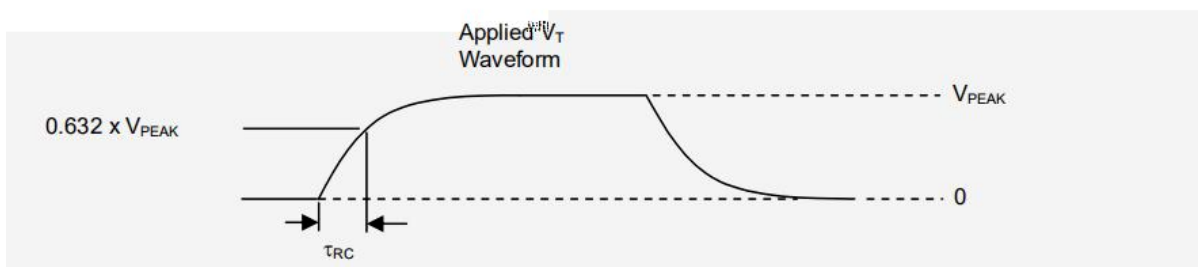
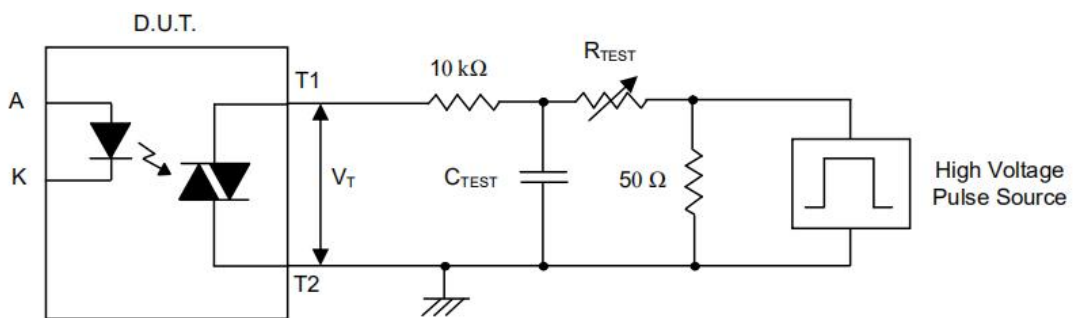
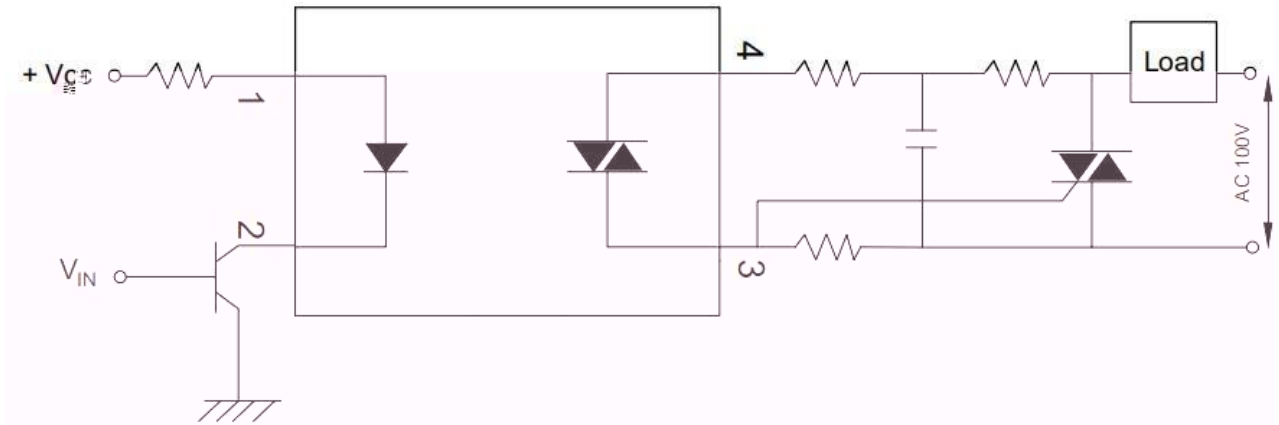
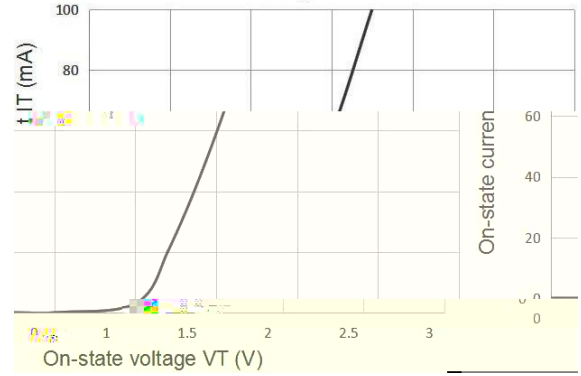

Fig.8 On-state current vs. On-state voltage



Measurement Method

The high voltage pulse is set to the required V_{PEAK} value and applied to the D.U.T. output side through the RC circuit above. LED current is not applied. The waveform V_T is monitored using a x100 scope probe. By varying R_{TES} the dv/dt (slope) is increased, until the D.U.T. is observed to trigger (waveform collapses). The dv/dt is then decreased until the D.U.T. stops triggering. At this point, τ_{RC} is recorded and the dv/dt calculated.

$$dv/dt = \frac{0.632 \times V_{PEAK}}{\tau_{RC}}$$

$$dv/dt = \frac{0.632 \times V_{PEAK}}{\tau_{RC}}$$

For example, $V_{PEAK} = 600V$ for EL306X series. The dv/dt value is calculated as follows:

$$dv/dt = \frac{0.63 \times 600}{\tau_{RC}} = \frac{378}{\tau_{RC}}$$